



*Full-operating
condition inverter*
V-FORCE



Modular Inverter Air-cooled Chiller (Heat Pump)

TCAV
FORM NO.A14720G01



R410A



Established in 1991,

TICA is a professional enterprise specialized in R&D, manufacturing, sales and services of environment cleaning and thermal energy utilization.

Vision

Strive to be the international leading integrated system and service provider in clean environment and utilization of thermal energy

Mission

Persist to maximize the value for customers through innovative technology and provide clean environment in order to improve the quality of life

TICA is a national high-tech enterprise, a single leading enterprise cultivated by the Ministry of Industry and Information Technology, a national brand cultivation enterprise of the Ministry of Industry and Information Technology, and a vice chairman member of China Refrigeration and Air-conditioning Industry Association. It has a national-recognized enterprise technology center, an enterprise academician workstation, and a post-doctoral research workstation. Its projects cover Beijing Bird's Nest Stadium, Water Cube, Wukesong Indoor Stadium, PetroChina, Sinopec, State Grid, Nanjing Panda, Hangzhou Xiaoshan International Airport, Hainan Airlines Group, Shangri-La Hotel, Manila Ocean Park, Abu Dhabi Al Muneera, SM City in Philippines and Unilever, etc.

TICA is also the outstanding provider of central air conditioners for China's subway networks and has successfully served nearly 70 key subway lines in major cities such as Beijing, Shanghai, Guangzhou, Shenzhen, Chengdu, Suzhou, Hangzhou and Tianjin. TICA is a professional supplier and service provider in China that specializes in system integration of clean environment. While for microelectronics, hospital operating rooms, biopharmaceutical industry and other professional purification areas, each achieving a market share of over 40%.

TICA, Visible Cleanness
TICA, Visible Energy-Saving



More than **70** branches, **5** manufacturing bases, and **8** factories nationwide

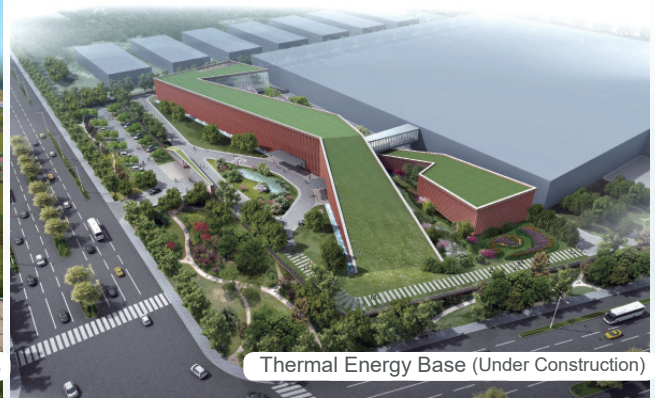

TICA modular unit represents **two decades** of technological capability accumulation

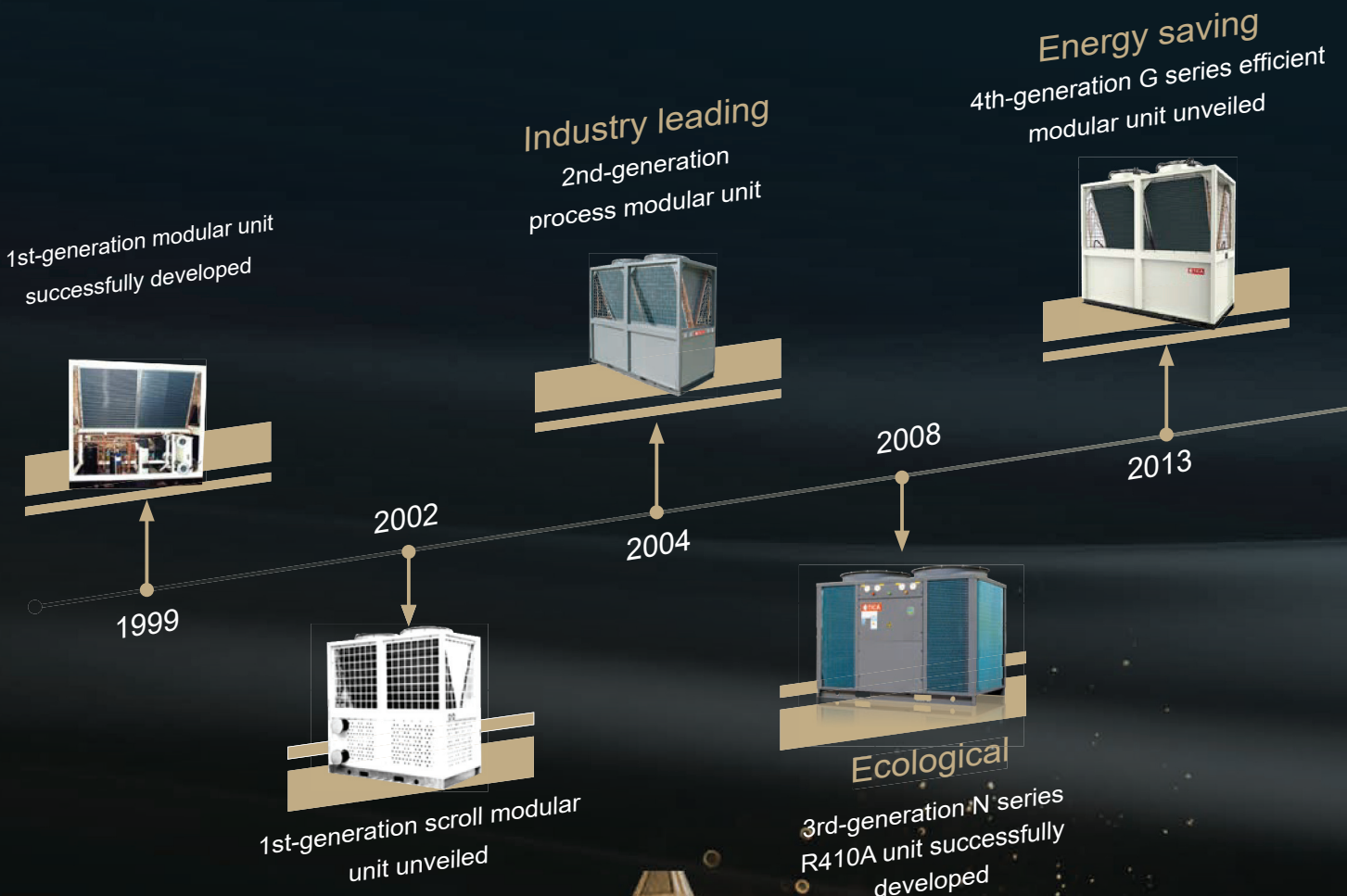

Modular inverter air-cooled chiller (heat pump)

Upgraded 7th-generation units, leading
an energy saving revolution
**V-FORCE full-operating
condition inverter**

Extensive lineup

6th-generation X series units unveiled
Solutions to meet special process and
sanitary conditions, normal indoor use,
cooling only, low temperature and strong
heat, four-pipe, full heat recovery

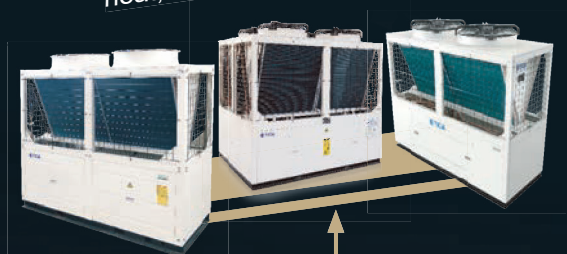

2014

2016-2019

2020



Targeted marketing

5th-generation H/J
series modular units
Unparalleled comfort/processing

Nomenclature

TCAV 065 B HE

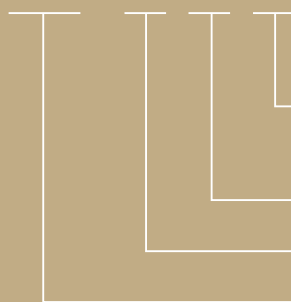

Feature: H: cooling/heating C: cooling only

HE: strong-cold, strong-heat, high-efficiency type

Design S/N: B, C, D...

Specification code: 035, 065, 130

Modular inverter air-cooled chiller (heat pump)

Cases

Common indoor use

Quiet and comfortable/heating at low temperature/full heat recovery



Modular inverter air-cooled chiller (heat pump)

Process application

Industrial temperature control/cooling only/process cooling

Electronic purification



Health care



Pharmaceutical industry



Laboratory test



- Huoshenshan Hospital
- Affiliated Hospital of Putian University
- Uzbekistan Mobile Cabin Hospital
- Drum Tower Hospital
- Nanjing General Hospital of People's Liberation Army
- The First People's Hospital of Zhengzhou City
- Wuhan Children's Hospital
- Xi'an No. 3 Hospital
- The First Affiliated Hospital of Xi'an Jiaotong University
- The First Affiliated Hospital of School of Medicine of Zhejiang University

- Dongshan Precision
- Goertek
- Foxconn
- Holitech
- Compal Electronics
- AAC Technologies
- OFILM
- Omron
- Risen Energy
- Silan

- Double Crane Pharmaceutical
- Sihuan Pharmaceutical
- CSPC
- Livzon Pharm
- Jingxin Pharmaceutical
- Kangmei Pharmaceutical
- Tasly Pharmaceutical
- Bright Future Pharmaceutical Laboratories
- Kanion Pharmaceutical
- Xianju Pharmaceutical

- Institute of Biophysics, Chinese Academy of Sciences
- Hefei General Electrical and Mechanical Product Testing Institute
- Shenzhen Academy of Metrology & Quality Inspection
- Henan Institute of Metrology
- Lianyungang Drug Administration
- Ningxia Food and Drug Administration
- Changsha Center for Disease Control and Prevention
- DNA Testing of Nanjing Public Security Bureau
- Animal Research Center of Medical School of Nanjing University
- GTTC

Excellence in All Aspects

Operate under all conditions

Operate at -26°C to +55°C
Performance improved by 20% at
extreme conditions

Full inverter energy saving

Dual grade-1 IPLV for cooling and heating
IPLV comprehensive energy
saving rate up to 26%

Various application scenarios

Solutions to meet normal indoor use, special
process and sanitary conditions, cooling only,
low temperature and strong heat, etc.
Full application scenario alternative



imple but Stunning

Concise structure

- Full concealed design
- Four-way air return
- Ivory white coating

Simplified system

- Single compressor design
- Optimized refrigerant pipeline

User-friendly experience

- Full series compatibility of modular unit
- Easy-to-use control panel (optional), one-key operation
- Data control, convenient after-sales service



Operate under all conditions

With years of experience in developing and designing process air conditioners, TICA has successfully integrated EVI and full inverter technologies and made a breakthrough in the operation of modular units.

Operating temperature in cooling mode: -20 to +55°C

Operating temperature in heating mode: -26 to +55°C

Performance improved by 20% at extreme conditions



1 **Dynamic control of condensation pressure**

Efficient inverter fan and 15%-100% stepless capacity control to match changes in the system pressure in real time.



2 **Inverter EVI technology**

Inverter adjustment under partial load ensures efficient operation;
EVI technology ensures strong cold and strong heat at extreme conditions.



3 **Self-developed drive control program**

German stepless sine-wave permanent magnet motor driving technology provides computing at 8000 times per second and double filtering to ensure that power disruption is removed at all frequencies.

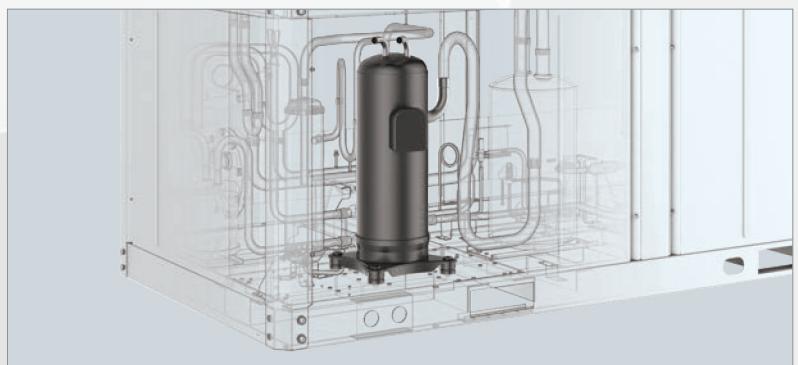

Modular inverter air-cooled chiller (heat pump)

Full inverter energy saving

V-FORCE modular units use full inverter design so that the partial load efficiency is greatly enhanced.

With patented control technology, multiple units are able to operate at the same time in a stable, efficient and balanced manner.

Reaching the national EEI level 1 in cooling and heating mode

IPLV is above 4.55 in cooling mode
exceeding the national EEI level 1 (4.0)

IPLV is above 3.10 in heating mode
meeting the national EEI level 1 for heating of the new national standard

*The cooling performance complies with GB 19577-2015

*The heating performance complies with GB 37480-2019



Energy Efficiency Curves of V-FORCE/Average Modular Units During Operation

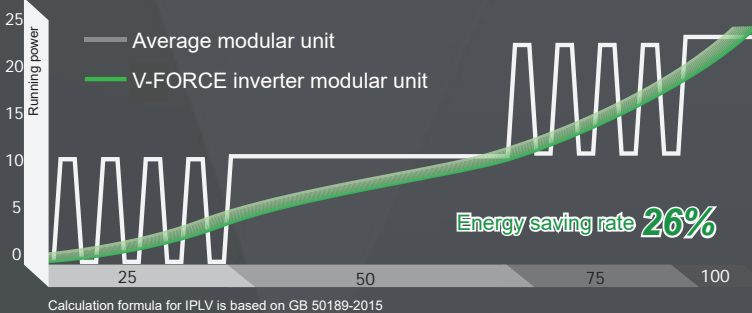

Inverter operation and accurate output

The unit is equipped with a large-capacity inverter compressor that supports 15%-100% stepless regulation. The unit has a smooth performance curve. In addition, it performs well under partial load and the compressor does not start or stop frequently.

Energy Efficiency Curves of Variable and Fixed Speed Modular Units During Operation (Five Sets)

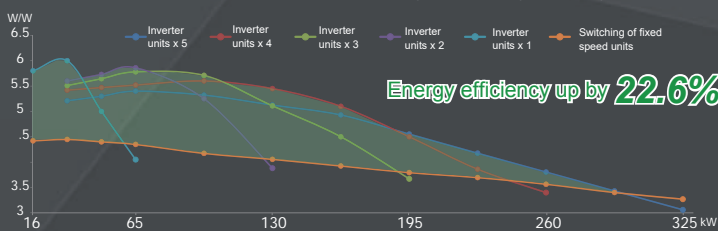

Balanced control to ensure energy efficiency

Partial load operation prioritized
When multiple modules are combined, the frequency of each compressor is intelligently controlled, so that the system operates in an energy-efficient area in a balanced manner.

Various application scenarios

Comfort

Silent and environmentally friendly
Extremely comfortable



The noise can be lowered by 6-10 dB(A) in silent mode
The noise can be as low as 50 dB(A) in partial load

Process

Perennial cooling
Stable operation

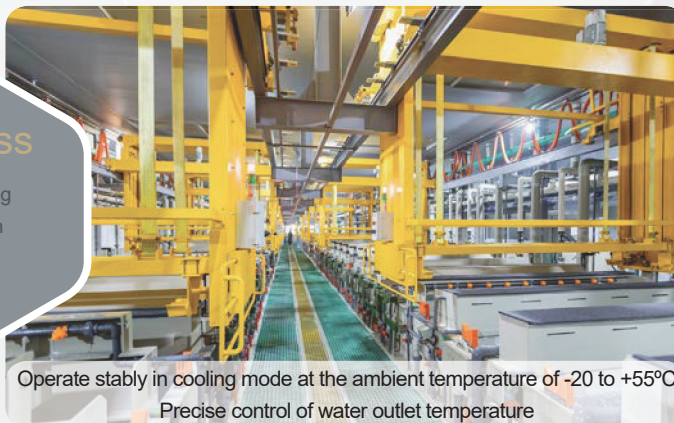

Operate stably in cooling mode at the ambient temperature of -20 to +55°C
Precise control of water outlet temperature

Strong heat

Low temperature and strong heat
EVI and enhanced efficiency



Heat at even -26°C (water outlet temperature at 0°C)
The water outlet temperature can reach 55°C
(when the ambient temperature is above 0°C)



Modular inverter air-cooled chiller (heat pump)

Simple but Stunning

Concise structure

- ◆ Vulnerable parts fully concealed to facilitate installation
- ◆ Four-way air return and 45% more windward area to ensure more efficient heat exchange and reliable structure
- ◆ TICA classical "ivory white" coated metal sheet framework

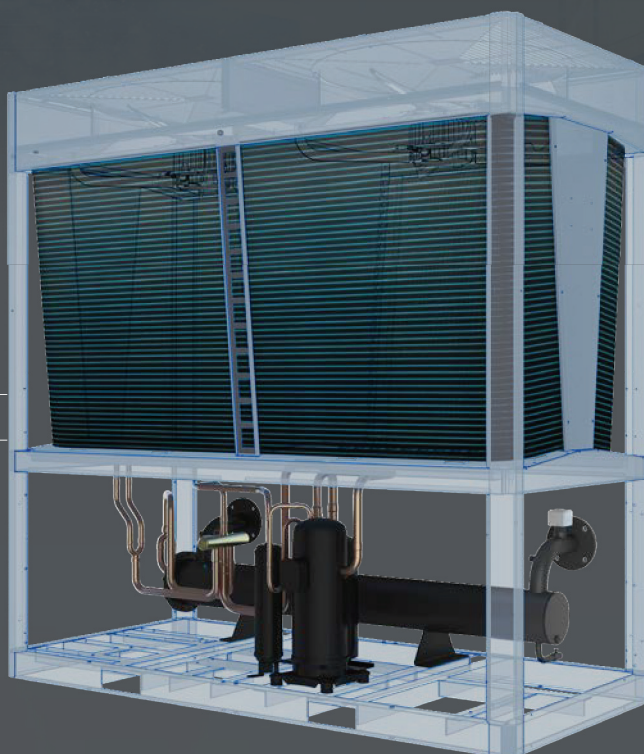

Simplified system

- ◆ Creative single compressor design featuring inverter and EVI technologies
- ◆ Optimized refrigerant pipeline to reduce welding costs

User-friendly experience

- ◆ Installation – full series compatibility of modular unit
- ◆ Usage – easy-to-use control panel (optional), one-key operation
- ◆ After-sales service – standard memory module and ten-year data management



Technical Specifications

Performance Data

Model			TCAV035BHE	TCAV065BHE
Nominal cooling	Cooling capacity	kW	33.5	65.0
	Power consumption	kW	12.0	21.2
	COP	W/W	2.79	3.06
	IPLV	W/W	4.60	4.55
Nominal heating 1	Heating capacity	kW	24.0	48.0
	Power consumption	kW	10.2	20.5
	COP	W/W	2.35	2.34
	IPLV	W/W	3.20	3.10
Nominal heating 2	Heating capacity	kW	34.0	75.0
	Power consumption	kW	10.5	23.4
	COP	W/W	3.24	3.20
Power supply	–	380 V 3N–50 Hz		
Water flow	m ³ /h	5.76	11.2	
Water resistance	kPa	30	45	
Water inlet and outlet pipe connection type	–	DN40 external thread connection	DN65 flange connection	
Operating mode	–	Automatic operation controlled by microcomputers		
Compressor	Type	–	Scroll type DC inverter EVI	
	Qty	Set	1	1
Fan	Type	–	DC inverter low-noise axial flow fan	
	Air flow	m ³ /h	13000	26000
	Qty	Set	1	2
Refrigerant	Type	–	R410A	
External Dimensions (Length * Width * Height)		mm	1170×846×1694	2000×950×2020
Weight	Net weight	kg	285	600
	Operating weight		300	660
Noise		dB(A)	50 - 61	50 - 67
Maximum total power		kW	20	31.5
Maximum operating current		A	30.5	50

- ★ Notes:
- The nominal cooling capacity and nominal cooling consumption power are tested at the rated water flow, water outlet temperature of 7°C, and outdoor dry-bulb temperature of 35°C.
The nominal heating capacity 1 is tested at the rated water flow, water outlet temperature of 41°C, and outdoor dry-bulb temperature of -12°C and wet-bulb temperature of -14°C.
The nominal heating capacity 2 is tested at the rated water flow, water outlet temperature of 45°C, and outdoor dry-bulb temperature of 7°C and wet-bulb temperature of 6°C.
 - About 6% loss caused by system pipelines, water pumps, valves, and dirt after unit installation shall be considered for the cooling (heating) capacity in actual applications.
 - The specifications are subject to change due to product improvement without prior notice.
 - Parameters listed in the above tables are for a single module. Up to 16 modules can be used together.
 - The control accessory box needs to be purchased separately, which contains the wired controller, wired controller communication cable, user manual, temperature sensor, etc. The box content may change. Please refer to the actual factory configurations.

Operating Range

Ambient temperature range in cooling mode	°C	-20 - 55
Ambient temperature range in heating mode	°C	-26 - 55
Cooling return water temperature	°C	10 - 25
Cooling water outlet temperature	°C	5 - 20
Heating return water temperature	°C	25 - 50
Heating water outlet temperature	°C	30 - 55

Modular inverter air-cooled chiller (heat pump)

Unit Selection Parameters Correction

Cooling Capacity Correction

TCVA035BHE

Water outlet temperature °C	Ambient Temperature (°C)																															
	55		52		48		44		40		35		30		25		15		5		0		-5		-10		-15		-20			
	Capacity (kW)	Power (kW)	Capacity (kW)	Power (kW)	Capacity (kW)	Power (kW)	Capacity (kW)	Power (kW)	Capacity (kW)	Power (kW)	Capacity (kW)	Power (kW)	Capacity (kW)	Power (kW)	Capacity (kW)	Power (kW)	Capacity (kW)	Power (kW)	Capacity (kW)	Power (kW)	Capacity (kW)	Power (kW)	Capacity (kW)	Power (kW)	Capacity (kW)	Power (kW)	Capacity (kW)	Power (kW)	Capacity (kW)	Power (kW)		
5	8.9	5.8	12.0	9.3	16.1	10.6	25.8	12.5	30.8	13.5	32.2	11.8	32.8	11.0	34.5	10.5	34.3	9.0	36.1	8.6	36.3	8.6	36.4	8.4	34.2	7.9	36.4	8.0	38.6	8.0		
7	7.2	6.0	12.6	9.3	18.3	10.9	26.8	12.6	32.1	13.5	33.5	12.0	34.7	11.1	36.3	10.6	36.0	9.1	37.2	8.6	37.3	8.7	37.4	8.6	35.7	8.0	37.9	8.2	40.1	8.3		
9	7.8	6.2	13.6	9.4	20.5	11.2	27.8	12.7	33.4	13.6	35.4	12.2	36.6	11.2	38.1	10.6	37.8	9.1	38.2	8.7	38.3	8.8	38.3	8.8	37.1	8.2	39.4	8.4	41.6	8.7		
12	8.4	6.5	15.3	9.6	22.8	11.5	29.3	12.8	35.3	13.6	38.4	12.5	39.4	11.4	40.8	10.7	40.3	9.2	39.7	8.7	39.8	8.8	39.8	8.9	39.3	8.4	41.6	8.8	43.9	9.1		
15	9.5	6.8	18.0	9.8	25.0	11.8	30.8	13.0	37.2	13.7	41.3	12.8	42.3	11.6	43.4	10.8	42.9	9.3	41.3	8.8	41.3	8.7	41.3	9.0	41.5	8.6	43.8	9.1	46.1	9.6		
20	11.0	7.1	22.7	10.2	29.9	12.1	35.0	13.1	43.0	13.9	44.6	13.2	47.0	11.8	48.8	10.9	48.1	9.5	44.4	8.9	44.3	9.0	44.3	9.1	45.8	9.0	48.2	9.8	50.6	10.6		

TCVA065BHE

Water outlet temperature °C	Ambient Temperature (°C)																															
	55		52		48		44		40		35		30		25		15		5		0		-5		-10		-15		-20			
	Capacity (kW)	Power (kW)	Capacity (kW)	Power (kW)	Capacity (kW)	Power (kW)	Capacity (kW)	Power (kW)	Capacity (kW)	Power (kW)	Capacity (kW)	Power (kW)	Capacity (kW)	Power (kW)	Capacity (kW)	Power (kW)	Capacity (kW)	Power (kW)	Capacity (kW)	Power (kW)	Capacity (kW)	Power (kW)	Capacity (kW)	Power (kW)	Capacity (kW)	Power (kW)	Capacity (kW)	Power (kW)	Capacity (kW)	Power (kW)		
5	12.1	10.9	23.2	16.4	31.2	18.8	50.0	22.0	58.1	23.1	62.5	20.9	63.6	19.5	67.0	18.6	66.5	16.0	70.1	15.2	70.3	14.8	70.6	14.4	66.4	14.0	70.7	14.1	74.9	14.2		
7	12.8	10.9	24.4	16.5	35.5	19.3	52.0	22.2	60.5	23.2	65.0	21.2	67.3	19.7	70.4	18.7	69.9	16.1	72.1	15.3	72.3	14.9	72.5	14.5	69.2	14.2	73.5	14.5	77.8	14.7		
9	13.8	11.1	26.4	16.6	39.9	19.9	53.9	22.4	62.9	23.2	68.8	21.5	71.0	19.9	73.9	18.8	73.2	16.2	74.1	15.3	74.2	15.0	74.4	14.6	72.0	14.5	76.4	14.9	80.8	15.3		
12	15.5	11.2	29.6	16.9	44.2	20.4	56.8	22.6	66.4	23.4	74.5	22.0	76.5	20.1	79.1	18.9	78.3	16.3	77.1	15.5	77.2	15.1	77.3	14.7	76.2	14.8	80.7	15.5	85.1	16.2		
15	18.3	11.5	35.0	17.3	48.5	20.9	59.8	22.9	70.0	23.5	80.2	22.6	82.1	20.4	84.3	19.1	83.3	16.5	80.1	15.6	80.1	15.2	80.1	14.9	80.5	15.2	85.0	16.1	89.5	17.0		
20	23.0	12.0	44.0	18.0	58.0	21.3	68.0	23.1	81.0	23.9	86.5	23.2	91.3	20.9	94.7	19.3	93.4	16.8	86.1	15.8	86.0	15.5	85.9	15.2	88.9	16.0	93.6	17.3	98.2	18.7		

Heating Capacity Correction

TCVA035BHE

Water outlet temperature °C	Ambient Temperature (°C)																															
	-26		-20		-15		-10		-5		0		7		10		15		20		25		30		35		48		55			
	Capacity (kW)	Power (kW)	Capacity (kW)	Power (kW)	Capacity (kW)	Power (kW)	Capacity (kW)	Power (kW)	Capacity (kW)	Power (kW)	Capacity (kW)	Power (kW)	Capacity (kW)	Power (kW)	Capacity (kW)	Power (kW)	Capacity (kW)	Power (kW)	Capacity (kW)	Power (kW)	Capacity (kW)	Power (kW)	Capacity (kW)	Power (kW)	Capacity (kW)	Power (kW)	Capacity (kW)	Power (kW)	Capacity (kW)	Power (kW)		
30	16.0	8.1	20.0	8.7	24.0	9.2	26.9	9.0	30.5	9.0	34.0	8.5	35.7	8.5	40.0	8.8	40.5	9.0	40.1	7.8	39.8	6.7	42.9	6.4	46.1	6.5	49.0	5.9	51.0	6.1		
35	15.9	9.0	19.8	9.1	23.7	9.7	26.9	9.9	30.1	10.1	33.0	9.3	34.3	9.0	39.2	9.1	40.4	9.1	40.1	7.9	39.7	6.7	42.8	6.4	46.0	6.5	49.0	5.8	51.0	5.8		
40	15.5	10.2	19.6	9.7	23.4	10.8	26.9	11.0	30.3	11.2	32.8	10.1	33.6	9.5	38.9	10.0	40.4	10.4	39.0	9.1	37.5	7.9	40.4	7.6	43.3	7.7	43.5	6.7	45.5	6.9		
45			19.3	11.6	22.6	11.9	26.3	12.1	29.9	12.3	32.2	11.2	34.0	10.5	38.5	11.1	40.4	11.6	39.5	9.4	38.6	7.3	41.6	7.0	44.5	7.1	44.8	6.2	46.8	6.4		
50			19.2	13.3	21.8	13.5	25.7	13.5	29.5	13.4	31.8	12.2	32.4	11.6	38.2	12.2	40.3	12.9	38.4	10.7	36.5	8.5	39.3	8.2	42.1	8.3	42.1	8.1	44.1	8.3		
55												31.3	12.0	32.0	11.1	38.0	12.6	40.3	14.1	37.8	11.9	35.4	9.6	38.1	9.4	35.4	9.5	36.2	7.2	37.0	7.3	

TCVA065BHE

Water outlet temperature °C	Ambient Temperature (°C)																															
	-26		-20		-15		-10		-5		0		7		10		15		20		25		30		35		48		55			
	Capacity (kW)	Power (kW)	Capacity (kW)	Power (kW)	Capacity (kW)	Power (kW)	Capacity (kW)	Power (kW)	Capacity (kW)	Power (kW)	Capacity (kW)	Power (kW)	Capacity (kW)	Power (kW)	Capacity (kW)	Power (kW)	Capacity (kW)	Power (kW)	Capacity (kW)	Power (kW)	Capacity (kW)	Power (kW)	Capacity (kW)	Power (kW)	Capacity (kW)	Power (kW)	Capacity (kW)	Power (kW)	Capacity (kW)	Power (kW)		
30	31.2	15.9	39.0	16.5	44.7	16.8	50.2	17.3	59.2	17.9	67.8	18.3	75.9	18.4	81.0	18.5	81.8	18.2	81.9	16.5	65.0	11.5	70.2	11.0	75.4	11.2	80.1	10.2	82.1	10.4		
35	30.9	17.7	38.5	18.4	44.7	18.3	49.7	18.8	59.2	19.6	67.2	20.1	75.9	19.9	80.8	20.5	81.8	20.0	82.6	17.6	65.7	12.6	70.9	12.1	76.1	12.3	81.1	10.6	83.1	10.8		
40	31.0	19.4	37.6	20.2	44.9	19.8	49.2	20.6	59.2	21.3	66.1	21.9	75.9	21.4	80.6	22.1	81.8	21.6	81.3	18.9	67.9	13.9	73.1	13.4	78.3	13.6	78.6	11.8	80.6	12.0		
45			36.6	22.0	44.7	21.6	48.6	23.0	58.9	23.8	65.5	23.7	75.0	23.4	80.4	23.6	81.8	23.5	82.0	20.1	68.1	15.1	73.3	14.6	78.5	14.8	79.0	12.8	81.0	13.0		
50					45.2	23.6	49.7	25.2	58.9	26.1	65.0	25.5	73.8	25.1	80.1	25.8	81.9	25.3	80.7	21.4	67.6	16.4	72.8	15.9	78.0	16.1	78.1	13.8	80.1	14.0		
55												65.0	27.5	73.8	26.7	79.9	27.4	81.6	27.4	78.1	22.7	67.1	17.7	72.3	17.2	67.1	17.4	78.0	14.8	80.0	15.0	

Unit Dimensions

TCAV035BHE

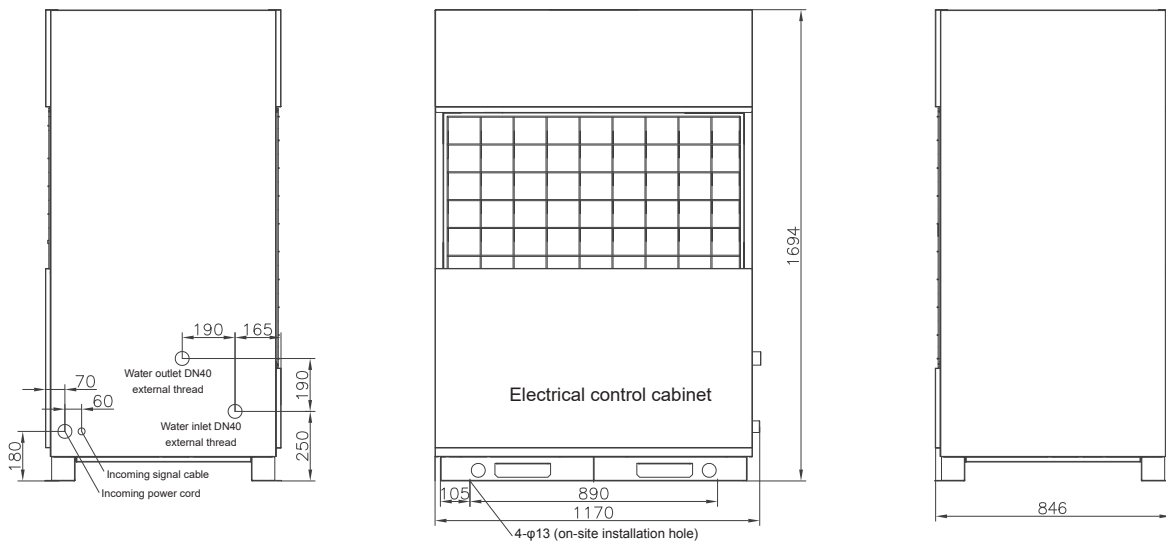

TCAV065BHE

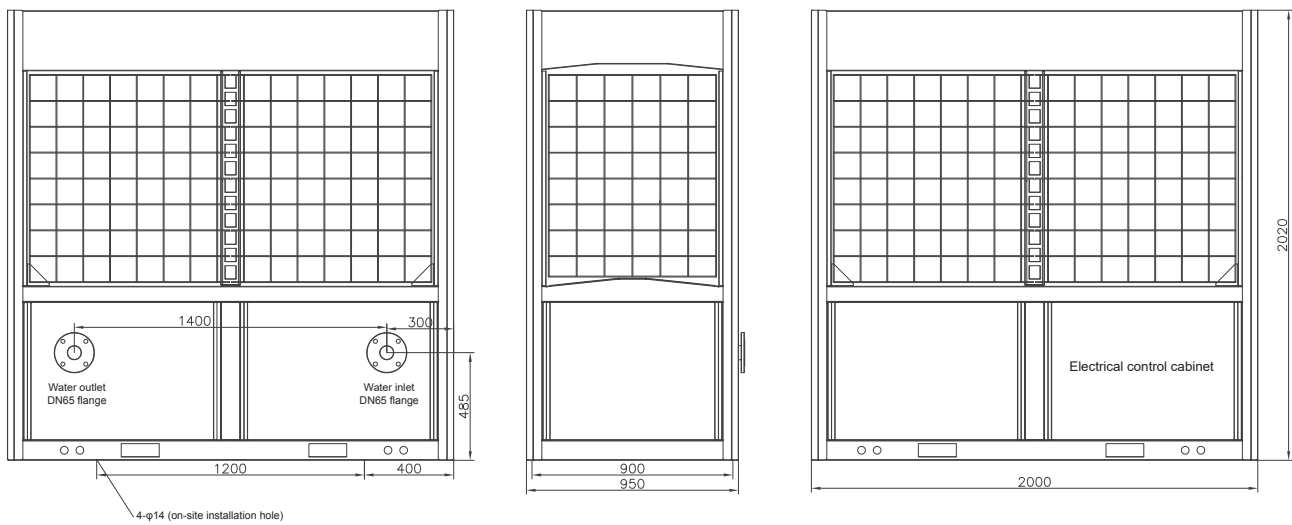

Unit Installation Instructions

Lifting notes

- 1) After a unit is delivered from the factory to the installation site, keep the proper package before hoisting.
- 2) Handle with care to ensure the unit is vertical.
- 3) Keep the unit away from other objects during lifting process. No person is allowed to stand below or near the unit for the sake of safety.
- 4) To prevent scratching or deforming the unit surface, protective pads must be placed on the contact part between the steel ropes and the machine body, and supports should be added between the ropes to prevent the rope from damaging the machine.
- 5) For how to select steel pipes for hoisting, steel ropes or cranes, please refer to the table of technical specifications. During the lifting process, avoid crash against the water inlet and outlet pipes of the unit.

TCAV035BHE

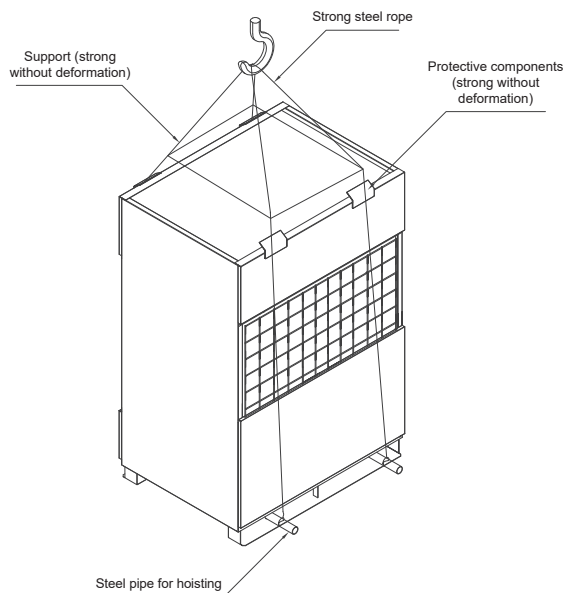

TCAV065BHE

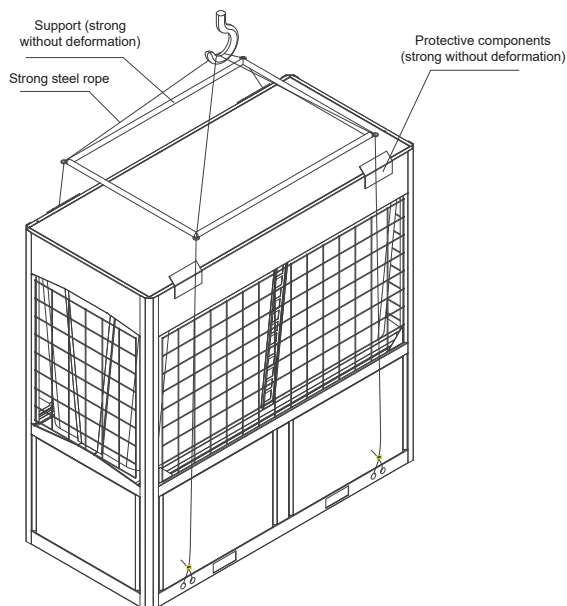

Unit installation space requirements

TCAV035BHE

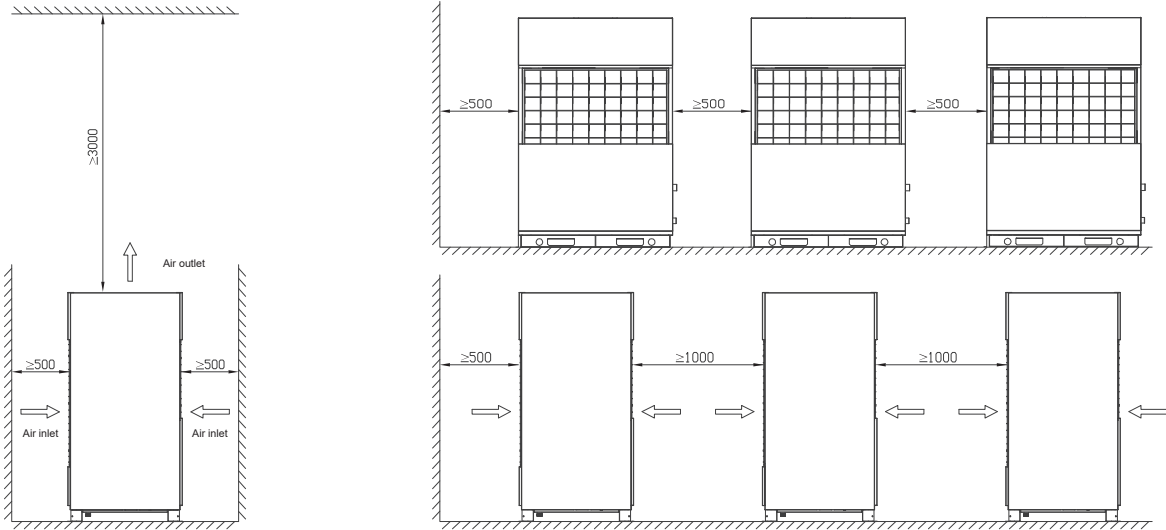

TCAV065BHE

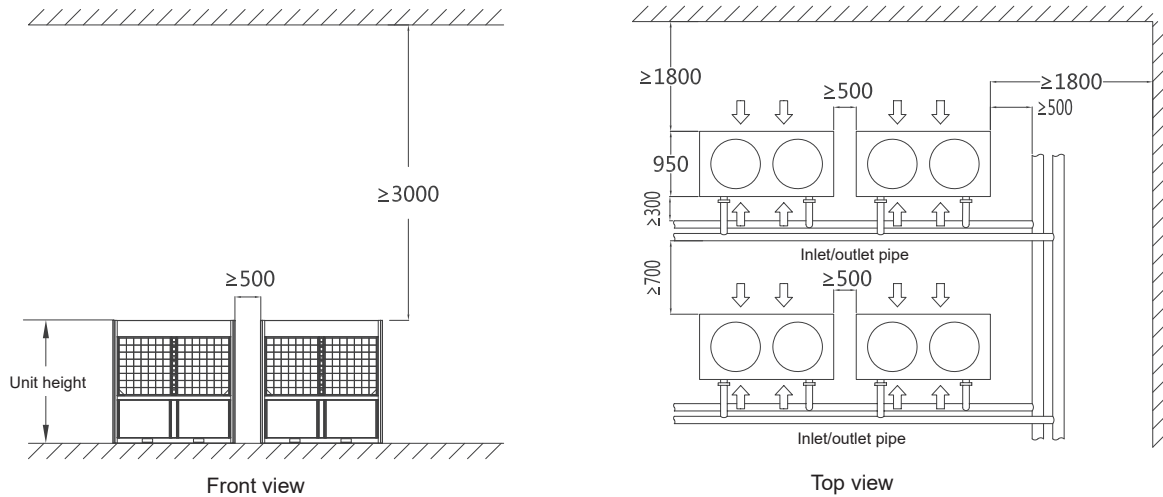

★ Notes:

1. For units below 80RT, DN100 pipe is recommended as main outlet pipe and installed in the same section.
2. For 80-160RT units, DN125 pipe is recommended as main outlet pipe and installed in the same section.
3. For 160-240RT units, DN150 pipe is recommended as main outlet pipe and installed in the same section.
4. For 240-500RT units, DN200 pipe is recommended as main outlet pipe and installed in the same section.
5. The water inlet and outlet pipes of the unit: For pipe dimensions, please refer to the specifications table. The main water pipe should be installed according to the actual installation conditions.

Modular inverter air-cooled chiller (heat pump)

Unit installation foundation drawing

TCAV035BHE

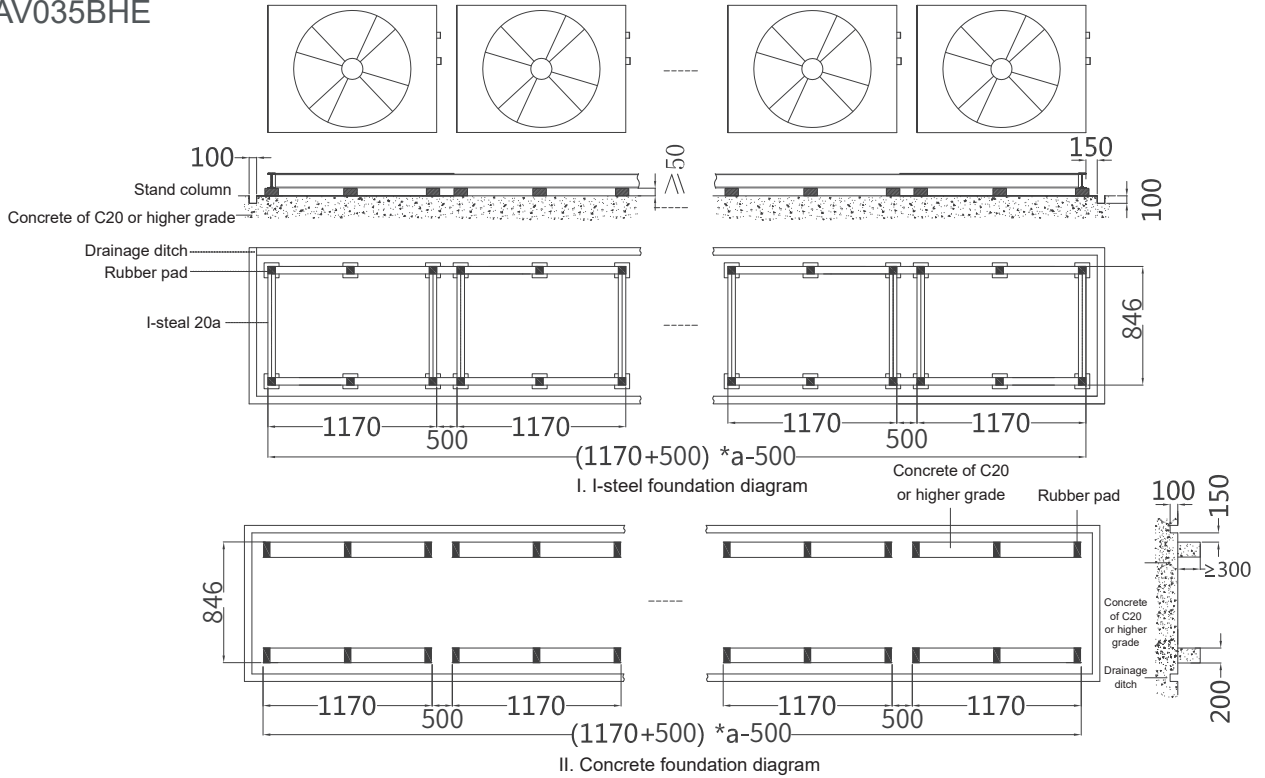

TCAV065BHE

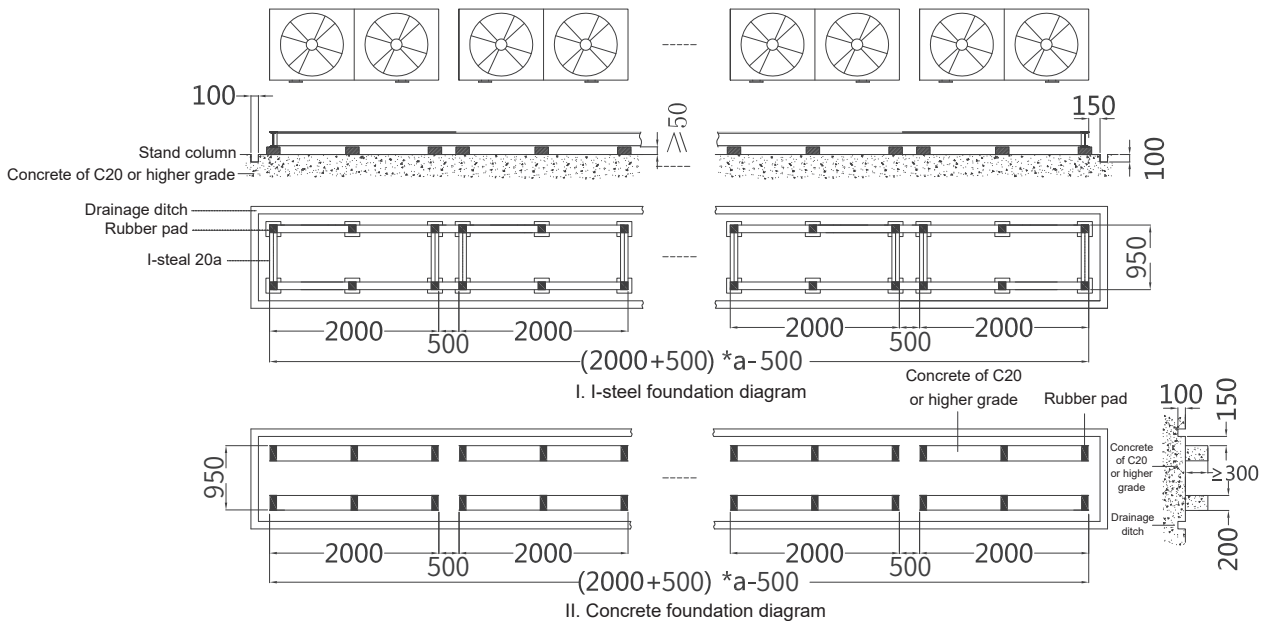

- a. a indicates the number of modules of different models.
- b. The foundation is made of reinforced concrete or channel steel frame, and is capable of bearing the weight of no less than 500kg/m^2 .
- c. Use rubber damping pads or shock absorbers with the thickness not smaller than 20 mm between the unit base and the foundation.
- d. Use M10 bolts to fasten the unit to the foundation.

- e. The foundation surface must be flat and horizontal and drains need to be reserved around the foundation.
- f. For I-steel foundation, use stand columns to elevate the drainage; for reinforced concrete foundation, build foundations separately for each unit. Drainage should also be separated. In snowy places the foundation should be elevated and drainage capacity should be increased. For details, see anti-freezing measures described in the instructions.

Instructions on Electrical Wiring of the Unit

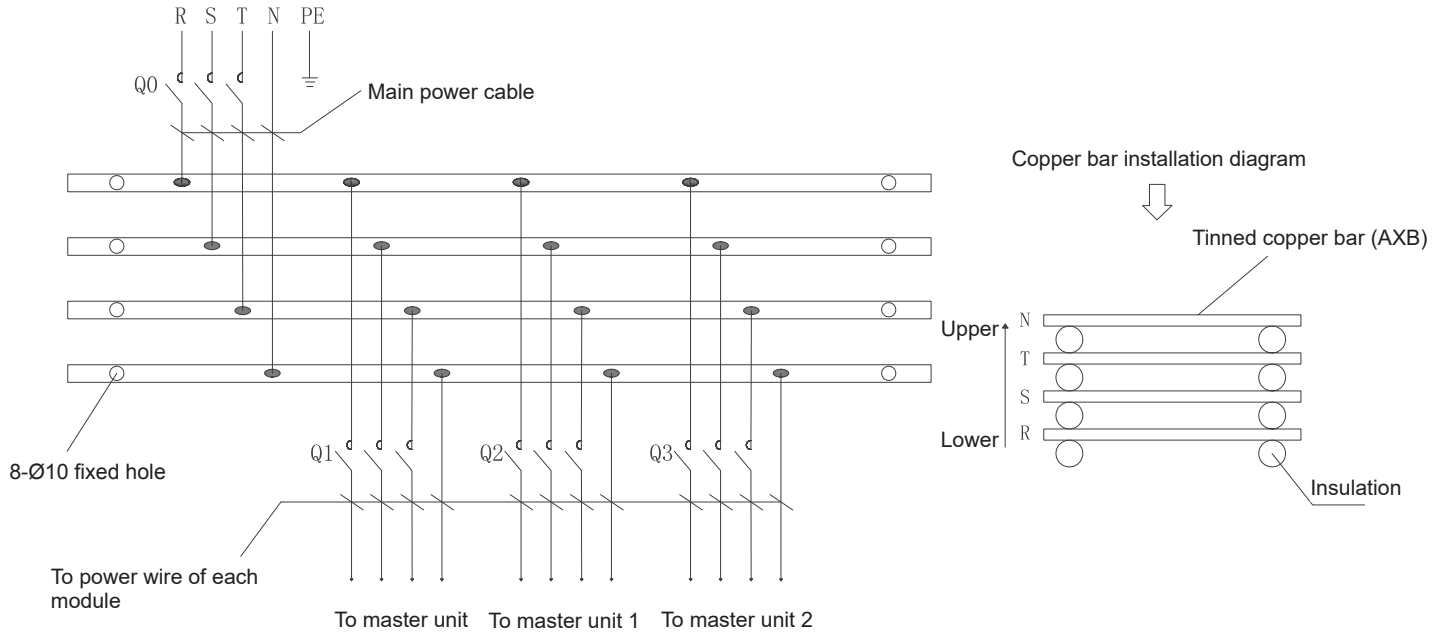

Wiring requirements Model	Maximum operating current (A)	Minimum cross-sectional area of power wire (mm ²)			Circuit breaker capacity (A)	Communication line	Copper bar size (A x B)
		Phase line	Neutral line	GND			
TCAV035BHE	30.5	10	10	10	40	The wire for connecting the chiller and the remote controller is a 4-core communication wire and the standard length is 30 m. The wire for connecting the units is a 2-core communication wire and the standard length is 8 m.	The cross-sectional area of the copper bar (A x B) shall not be smaller than the square of the main power wire.
TCAV065BHE	50	16	16	16	63		

★ Notes:

- The power supply for the unit is 380V 3N-50Hz.
- Q0 and Q1/Q2/Q3 are circuit breakers and type D circuit breaker is recommended.
- Consider water pumps and other loads during installation, and select circuit breakers, power wires, and copper bars based on the actual situation.
- Copper bars are installed vertically. See the Electrical Wiring Diagram.
- Copper bars are not required for less than two modules.
- Only power cord terminals are reserved. All the electrical parts in the above figure are configured by the customer.
- The power cord is to be provided by the customer on site. The main power cord must comply with the national electrical installation standard.
- The recommended power cord specifications are based on the ambient temperature of 30°C in the air, 20°C on the ground and multi-core PVC cable of 70°C when it is arranged in the cable tray in an exposed manner (GB/T 16895.15-2002, Table 52-C3). The power cord specifications may be subject to adjustment in light of the national standards depending on the conditions of use.
- Current carrying capacity is calculated based on the case that the wire length is less than 20 meters, and it should be adjusted according to the corresponding national standards based on the actual wire length.
- The circuit breaker specifications are based on the ambient temperature of 30°C when the circuit breaker is working. The circuit breaker specifications may be subject to adjustment in light of the circuit breaker specifications document depending on the conditions of use.
- The communication cable must be shielded twisted pair and cannot be mixed with high voltage cables.

Installation Instructions of the Water System

Components of the water system

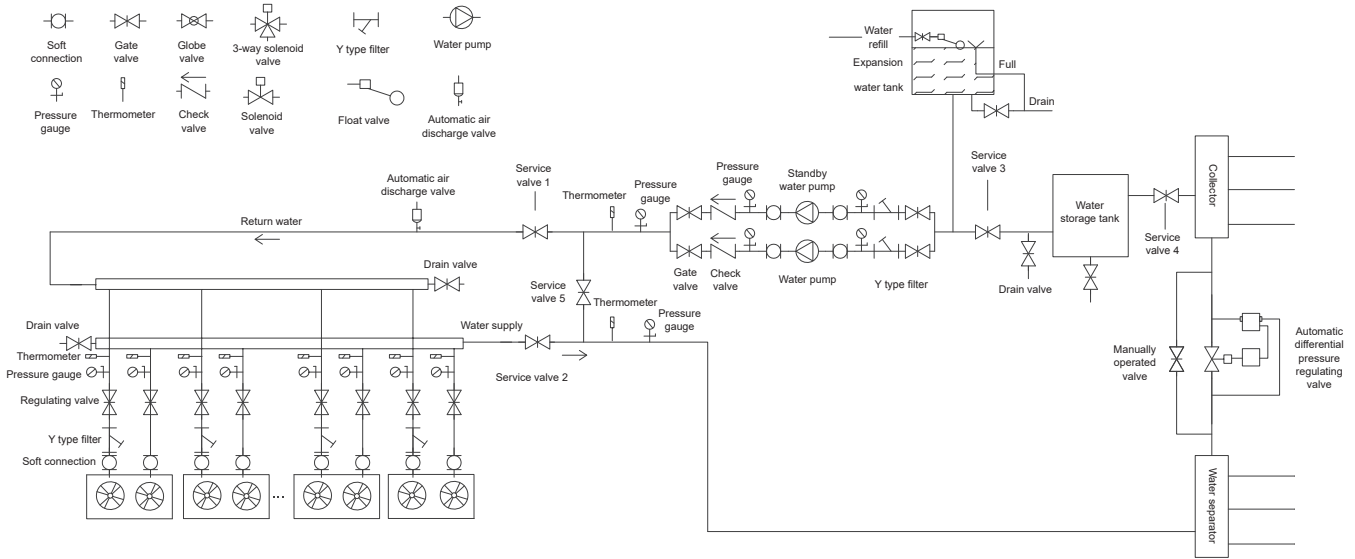

★ Notes:

- The figure shows the installation of the water system. The installation is subject to the construction drawings of the design institute.
- Water flow switches have been installed inside the unit and they do not need to be installed on site.
- The water system of the unit shall ensure that water flow is evenly distributed between units.
- Multiple water systems are often seen in large projects. They are typically designed in different areas. Overhaul or closure of water systems in certain areas may result in significant changes in load, so it is recommended to turn off any unit of them in this case.
- After successfully installing the water system, turn off the overhaul valves 1 and 2 and turn on the overhaul valve 5. Start the water pump and clean the water filter. Connect the water pipe to the unit and start operating the unit.
- Water pumps must be selected based on the flow and the required head. The water pump is generally installed on the main water inlet/outlet pipes of the unit. When the inlet pressure is greater than 1.0 MPa, it is recommended to install the water pump on the water outlet pipe. The water pump must be interlocked with the unit.
- The automatic differential pressure regulator can make the entire system work more stably.
- Manifold is used to distribute water flow of branch pipes more properly.
- A Y-type water filter needs to be installed on the water pipes (16-20 meshes/inch is recommended). Clean the unit after commissioning.
- Install a water flow regulating valve on each water inlet branch pipe of the unit, to regulate the flow of water entering each unit to be consistent.
- If an auxiliary heat source such as an auxiliary electric heater is used, install it on the main water outlet pipe of the unit.
- To ensure water resistance balance, install the unit in direct return manner.
- Valves 1, 2, 3, and 4 are used as overhaul valves, and valve 5 is used for cleaning the water pipes when the unit is commissioned or when water treatment is performed at the air side and at the pipes. In this case, close valve 1 and valve 2 and open valve 3, valve 4, valve 5, and water pump.
- Water inlet and outlet collection pipes of the unit should be such designed that the water flow is lower than 1m/s, and their diameter is larger than that of the water pipe of water system which they are connected to.
- Reserve sufficient space between modular chillers to guarantee ventilation.



Installation Requirements of the Water System

- Use softened water.
- The water system must be equipped with safety valves and automatic water supply valves.
- The water flow of the unit shall not be less than the nominal value indicated on the nameplate.
- The automatic air discharge valve must be installed at the highest point of the water system.
- An appropriate drain valve shall be installed at the lowest point of the water system.
- Install an expansion water tank to accommodate changes of the water volume caused by water temperature changes.
- The water system must be equipped with bypass valves. Only cleaned water system can be connected to the unit.
- Regularly clean the water system lest any impurities enter the evaporator and cause damage to the unit.
- Verify and confirm the total water capacity of the water system. Add an energy storage tank in case of any insufficiency. This can avoid water temperature fluctuation and frequent start and stop of the unit.

Operation Notes

- A dedicated power supply must be provided. Its voltage fluctuation range cannot exceed $\pm 10\%$ of the rated voltage indicated on the unit nameplate. The automatic air switches must be used and its setting current is 1.5 times of the unit's operating current. Configure inverse phase and open-phase protection. Never use knife switches.
- When the unit is used for the first time for the quarter, power on the unit and pre-heat the unit for 24 hours. If the ambient temperature is lower than 5°C or a power failure occurs, be sure to thoroughly drain water from the unit and pipeline. If the ambient temperature is lower than 5°C , ensure that the unit is energized, the water system is filled with water, and the chilled water circulating pump of the air conditioner must be interlocked with the modular chiller. In this way, the modular unit can automatically control the water pump operation or heating operation, thereby implementing automatic anti-freezing protection of the air conditioning water system. The purpose is to protect facilities such as the unit and water pipeline against damage caused by freezing of water in the pipeline of the air conditioning water system. When the ambient temperature is above 5°C , especially in summer, keep the unit full of water and ensure normal water pressure lest any air enter and corrode the pipes. Check the water quality before you turn on the unit next time. If the water quality is bad, replace the water and clean the filter.
- Do not start or close the unit more than six times per hour. Always keep the electric control cabinet dry.
- Keep the unit surroundings ventilated to ensure good heat exchange. Do not short circuit the unit's air discharge and air return. Clean the air-side heat exchanger on a periodic basis.
- The water system should be equipped with an expansion tank; the system circulating water must be clean; sufficient water flow should be maintained during operation (see the nameplate for details); otherwise, the water-side heat exchanger may be frozen. Remember to regularly clean the water filter.
- Arrange dedicated maintenance personnel and keep record.

Modular inverter air-cooled chiller (heat pump)

Routine Maintenance:

TICA recommends the user to record the routine operating data of air-conditioning equipment and regularly carry out maintenance.

1. Before using the unit for the first time, check the functioning of the air side equipment and other parts of the water system.
2. (Recommended) Use the following service schedule to maintain the unit:

Daily inspection	1. Check whether the unit generates any alarm
	2. Check whether the air discharge and air suction pressures and oil pressure are normal
	3. Check whether the oil level is acceptable (check the oil sight glass to ensure proper amount of oil)
	4. Check for any abnormal compressor or fan noise
	5. Check for odors inside the starter and control cabinet
	6. Check whether the temperature sensor and temperature probe are securely fixed
	7. Check for any appearance damage of the unit and whether heat exchanger or discharge fan is blocked
	8. Check whether the water pump and valve function normally
	9. Check the appearance of water pipe for damages and leakage
Monthly inspection	1. Check the color of the test paper in the sight glass of liquid supply pipe (yellow indicates that the refrigerant has excessive water content)
	2. Check for leakage in the refrigerant loop (whether there is any greasy dirt or sound of leaks)
	3. Check whether the water filter is clean, and whether the water flow switch and the water differential pressure switch work properly
	4. Check whether the control cabinet is securely wired, whether wiring terminals are clean, whether the unit leaks, and whether contactor works properly

★ Notes:

- ① Daily and monthly inspections are to be performed and recorded by the user.
- ② The replacement of consumable parts and materials is determined by the service life or operation duration of the unit. For units that operate all year around and those for the purpose of process, the operation duration should prevail; for units under normal operation and those for comfort, the service life should prevail.
- ③ It is recommended that the unit should be fully maintained every three years or every 3,000 hours of machine operation.

Summary of Unit Certification and Reporting

S/N	Product name	Model	Type of certification
1	Modular Inverter Air-cooled Chiller (Heat Pump)	TCAV035BHE, TCAV065BHE	Third-party inspection report
2	Modular Inverter Air-cooled Chiller (Heat Pump)	TCAV035BHE, TCAV065BHE	Authentication certificate of energy saving products



Follow the WeChat Official
Account of TICA to see more
solutions

4008-601-601

Nanjing TICA Climate Solutions Co., Ltd.
Address: No.6, Hengye Road, Nanjing Economic and Technological
Development Zone, China
Postal code: 210046
Tel: 86-25-85326977
E-mail: tica@ticachina.com

Note: Due to constant improvement and innovation of TICA's products, the product models, specifications and parameters contained in this document are subject to change without prior notice.